

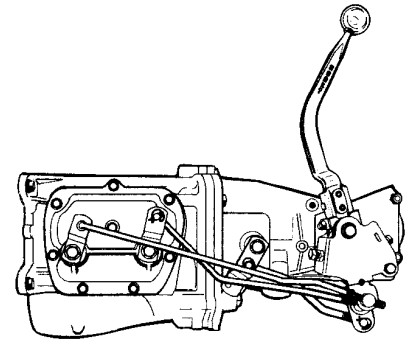

U.S. PATENT NO. 3,216,274 & NO. 3,306,126



HURST COMPETITION PLUS[®] FLOOR SHIFT
MUNCIE 4 SPEED TRANSMISSION

**DO NOT
Dis-assemble
Shifter Unit**

**Do Not Remove
Transmission
From Car**

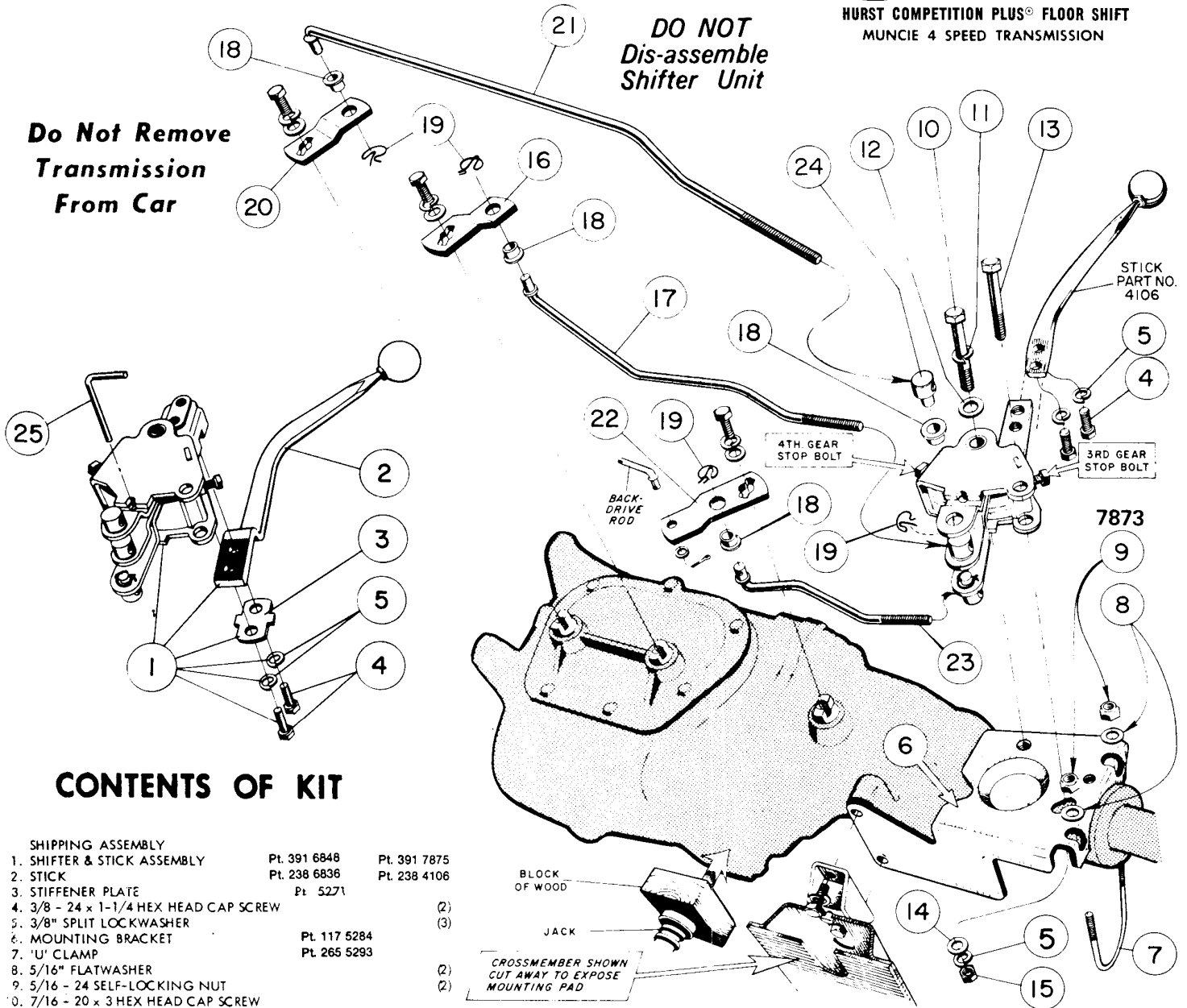

CONTENTS OF KIT

- | | | |
|--|------------------|--------------|
| 1. SHIFTER & STICK ASSEMBLY | Pt. 391 6848 | Pt. 391 7875 |
| 2. STICK | Pt. 238 6836 | Pt. 238 4106 |
| 3. STIFFENER PLATE | Pt. 5271 | |
| 4. 3/8 - 24 x 1-1/4 HEX HEAD CAP SCREW | | (2) |
| 5. 3/8" SPLIT LOCKWASHER | | (3) |
| 6. MOUNTING BRACKET | Pt. 117 5284 | |
| 7. 'U' CLAMP | Pt. 265 5293 | |
| 8. 5/16" FLATWASHER | | |
| 9. 5/16 - 24 SELF-LOCKING NUT | | |
| 10. 7/16 - 20 x 3 HEX HEAD CAP SCREW | | |
| 11. 7/16" SPLIT LOCKWASHER | | |
| 12. 7/16" FLATWASHER | | |
| 13. 3/8 - 24 x 3 HEX HEAD CAP SCREW | | |
| 14. 3/8" FLATWASHER | | |
| 15. 3/8 - 24 HEX NUT | Pt. 105 7129 | |
| 16. ARM - 1st/2nd | Pt. 213 5307 | |
| 17. ROD - 1st/2nd | Pt. 118 1681 (6) | (6) |
| 18. NYLON BUSHING | Pt. 97000015 (6) | (6) |
| 19. SPRING CLIP | Pt. 105 7130 | |
| 20. ARM - 3rd/4th | Pt. 213 2145 | |
| 21. ROD - 3rd/4th | Pt. 105 7128 | |
| 22. ARM - REVERSE | Pt. 213 3691 | |
| 23. ROD - REVERSE | | |
| 24. ROD ADJUSTING BUTTON | | (3) |
| 25. NEUTRAL ALIGNMENT ROD | Pt. 148 1725 | |

373 7131