

# **MSD<sup>™</sup>** **IGNITION** **INSTALLATION INSTRUCTIONS**

## **MSD Blaster GM Dual Tower Coil Pack PN 8224**

**IMPORTANT:** Read Instructions before attempting the installation.

### **Parts Included:**

1 - Blaster GM Dual Tower Coil Pack

**WARNING:** During installation, disconnect the battery cables. When disconnecting the battery, always remove the Negative cable first and install it last.

This MSD GM Dual Tower Coil is designed as a replacement coil and produces a high voltage spark. To get even more ignition performance, install an MSD DIS Series Ignition Control. To ease installation of a DIS Ignition use MSD's Coil Interface Modules, PN 8870 (See Figure 2).

1. Remove the coil wires and the two retaining screws.
2. Remove the factory coil.
3. Position the new MSD GM Dual Tower Coil to the module making sure the terminals are aligned.
4. Install the hold-down screws and plug wires.

**WARNING:** High Voltage is present on the coil terminals. DO NOT touch the coil terminals or tower when the engine is cranking or running.

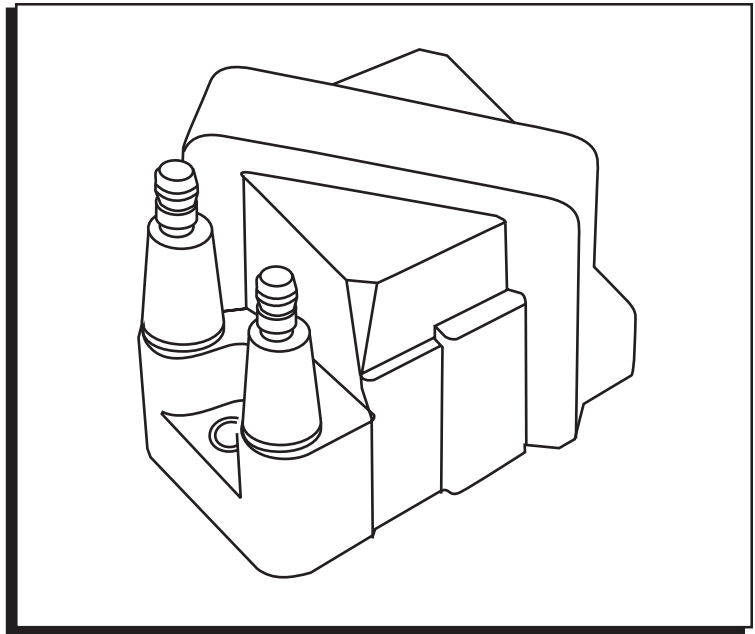

**Figure 1 The MSD GM Dual Tower Coil Pack.**

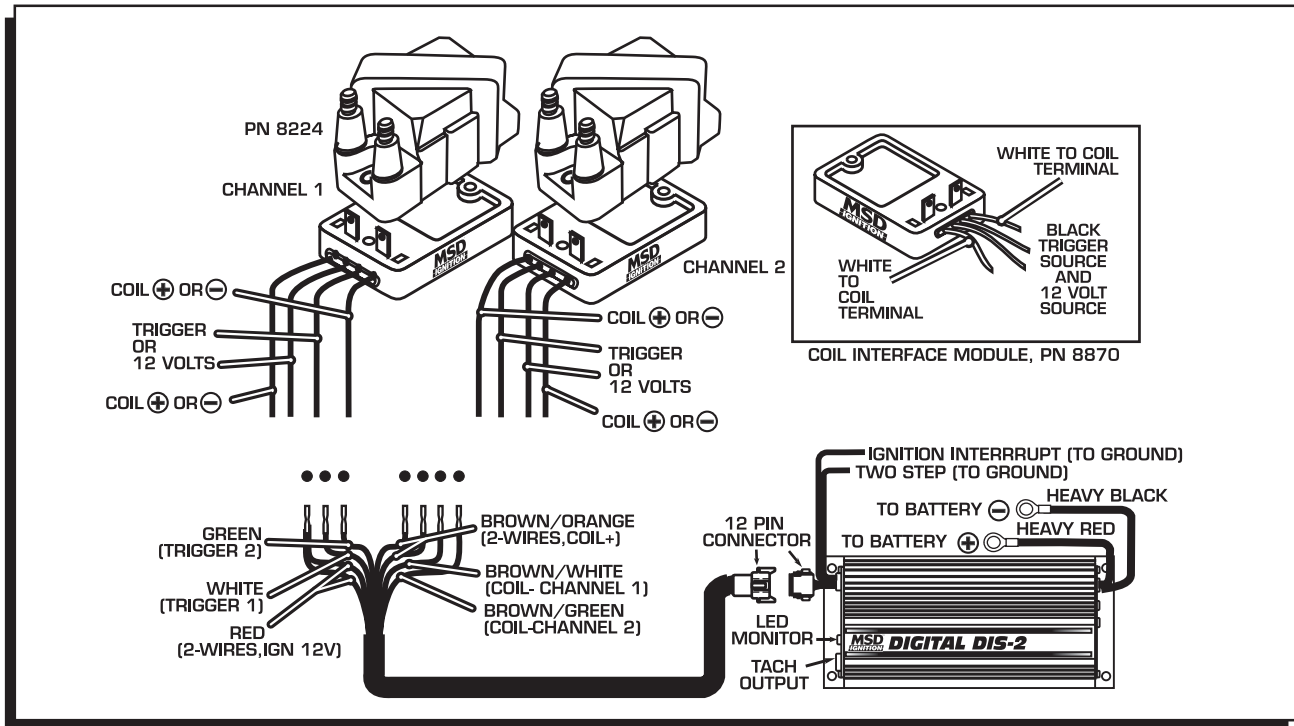

**Figure 2 Complete Installation with an MSD DIS-2 Ignition.**

### Service

In case of malfunction, this MSD component will be repaired free of charge according to the terms of the warranty. When returning MSD components for service, Proof of Purchase must be supplied for warranty verification. After the warranty period has expired, repair service is charged based on a minimum and maximum charge.

Send the unit prepaid with proof of purchase to the attention of: **Customer Service Department, Autotronic Controls Corporation, 12120 Esther Lama, Suite 114, El Paso, Texas 79936.**

When returning the unit for repair, leave all wires at the length in which you have them installed. Be sure to include a detailed account of any problems experienced, and what components and accessories are installed on the vehicle.

The repaired unit will be returned as soon as possible after receipt, COD for any charges. (Ground shipping is covered by warranty). All units are returned regular UPS unless otherwise noted. For more information, call the MSD Customer Service Line (915) 855-7123. MSD technicians are available from 8:00 a.m. to 5:00 p.m. Monday - Friday (mountain time).

### Limited Warranty

Autotronic Controls Corporation warrants MSD Ignition products to be free from defects in material and workmanship under normal use and if properly installed for a period of one year from date of purchase. If found to be defective as mentioned above, it will be replaced or repaired if returned prepaid along with proof of date of purchase. This shall constitute the sole remedy of the purchaser and the sole liability of Autotronic Controls Corporation. To the extent permitted by law, the foregoing is exclusive and in lieu of all other warranties or representations whether expressed or implied, including any implied warranty of merchantability or fitness. In no event shall Autotronic Controls Corporation be liable for special or consequential damages.